

# Angle Relief Valve, ASME AR4100 Series

## Application

The ASME approved 90° relief valves AR Series, provide precise relief set points which protect cryogenic vessels and piping systems for over-pressurization.

## Features

- High flow rates are approved by rigorous testing to ASME BVPC Code Section VIII.
- The ninety degree configuration provides relief of gases eliminating direct flow through the spring.
- The ninety degree configuration allows easy incorporation to plumbing for output containment.
- Bubble tight seat provides 100% shut off when reseating or static mode.
- A variety of inlets and pressure settings assure adherence to application requirements.
- Temperature Range: -320°F (-196°C) to +165°F (+74°C)
- Cleaned for Oxygen Service per CGA G-4.1
- 100% Factory Tested.
- PED, TPED, ASME & CRN Certified



## Materials

Body .....	Bronze ASTM B61
Upper Body .....	Stainless Steel ASTM A582
Seat & Stem .....	Brass ASTM B16
Poppet Guide .....	Brass ASTM B16
Spring Retainer .....	Brass ASTM B16
Adjusting Screw .....	Brass ASTM B16
Cap .....	Brass ASTM B16
Ball .....	Stainless Steel
Gasket .....	Copper ASTM B152-17
Spring .....	Stainless Steel ASTM A313
Seal .....	Modified PTFE

## Ordering Information

Fill in the blanks with options below.  
Example: AR4106A300

AR	4106	A	300
Angle Relief	Size	Cert Requirements and Pressure Unit	Set Pressure
			Size
			A,N-psig
			B-barg
			04=1/2"
			06=3/4"
			08=1"
			12=1 1/2"

Setpoint tolerance is ± 3% of the set pressure or ± 2 psi whichever is greater.

Note: For psig pressure settings, the part numbers end in A  
For barg pressure settings, the part numbers end in B

## Ordering Information

Part Number	Inlet Inches (mm)	Outlet Inches (mm)	Ends	A Inches (mm)	B Inches (mm)	C Inches (mm)	D Inches (mm)	E Inches (mm)	Set Pressure	ASME Flow Capacity (Air) at 110% Set Pressure	Weight Lbs (Kg)
AR4104A	1/2"	1"	Thread NPT	6.03"	1.97"	1.63"	1.63"	2.49"	250 psig	406 SCFM *	2.75 (1.25)
AR4104B	(15)								17.23 barg*	690 m³/hr	
AR4106A	3/4"	(20)	Thread NPT	(153.16)	(50.04)	(41.40)	(41.40)	(63.25)	250 psig*	451 SCFM	
AR4106B	(20)								17.23 barg*	766 m³/hr	
AR4108A	1"	1 1/4"	Thread NPT	6.88"	2.37"	2.00"	1.90"	3.01"	250 psig*	1,003 SCFM	3.75 (1.70)
AR4108B	(25)								(32)	(174.75)	
AR4112A	1 1/2"	2"	Thread NPT	9.64"	3.20"	2.45"	2.60"	3.89"	250 psig*	2,277 SCFM	8.00 (3.63)
AR4112B	(40)								(50)	(244.86)	

\*Custom psig and barg settings are available

Note: For Non-ASME stamp, the part numbers are: AR4104N, AR4106N, AR4108N, AR4112N.



AR4100 Series

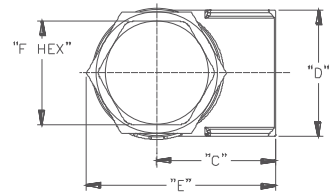
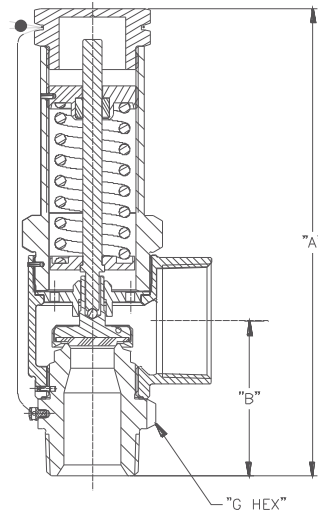

## Air Capacity = m x P

Where:

m = Slope Value

P = Pressure, Absolute @10% overpressure.

Example: Pressure relief valve, 1/2" inlet x 1" outlet, at 80 psi. Part number AR4108A080.

m = 1.4

P = 80 psi

Air Capacity = 1.4 x [(80psi x 1.10) + 14.7]

Air Capacity = 143.8 SCFM (air)

## Flow Performance

AR4104A set pressures 75 - 500 capacity is 1.4 SCFM of air per psi of flow pressure.

AR4106A set pressures 75 - 400 capacity is 1.56 SCFM of air per psi of flow pressure.

AR4108A set pressures 75 - 425 capacity is 3.463 SCFM of air per psi of flow pressure.

AR4112A set pressures 80 - 425 capacity is 7.86 SCFM of air per psi of flow pressure.

Flow pressure per ASME is 10% above set pressure or +3 psi, whichever is greater.

# Angle Relief Valve, ASME AR5100 Series

## Application

The ASME approved 90° relief valves AR Series, provide precise relief set points which protect cryogenic vessels and piping systems for over-pressurization.

## Features

- High flow rates are approved by rigorous testing to ASME BVPC Code Section VIII.
- The ninety degree configuration provides relief of gases eliminating direct flow through the spring.
- The ninety degree configuration allows easy incorporation to plumbing for output containment.
- Bubble tight seat provides 100% shut off when reseating or static mode.
- A variety of inlets and pressure settings assure adherence to application requirements.
- Temperature Range: -320°F (-196°C) to +165°F (+74°C)
- Cleaned for Oxygen Service per CGA G-4.1
- 100% Factory Tested.
- PED, TPED & ASME Certified



## Materials

Body .....	Bronze ASTM B61
Upper Body.....	Stainless Steel ASTM A582
Seat & Stem .....	Brass ASTM B16
Poppet Guide.....	Brass ASTM B16
Spring Retainer.....	Brass ASTM B16
Adjusting Screw.....	Brass ASTM B16
Cap .....	Brass ASTM B16
Ball.....	Stainless Steel
Gasket .....	Copper ASTM B152-17
Spring .....	Stainless Steel ASTM A313
Seal .....	Modified PTFE

## Ordering Information

Fill in the blanks with options below.

Example: AR5106A300

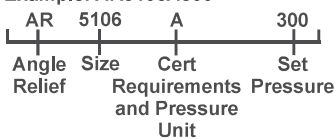

### Certifications

- A-ASME, TPED, PED
- B-ASME, TPED, PED
- N-TPED, PED
- : - B Version Assembled in Europe

<u>Set Pressure</u>	<u>Size</u>
A,N-psig	04=1/2"
B-barg	06=3/4"
	08=1"
	12=1 1/2"

Setpoint tolerance is ± 3% of the set pressure or ± 2 psi whichever is greater.

Note: For psig pressure settings, the part numbers end in A  
For barg pressure settings, the part numbers end in B

## Ordering Information

Part Number	Inlet Inches (mm)	Outlet Inches (mm)	Ends	A Inches (mm)	B Inches (mm)	C Inches (mm)	D Inches (mm)	E Inches (mm)	Set Pressure	ASME Flow Capacity (Air) at 110% Set Pressure	Weight Lbs (Kg)
AR5104A	1/2"	1"	Thread BSP	6.03"	1.97"	1.63"	1.63"	2.49"	250 psig*	406 SCFM	2.75 (1.25)
AR5104B	(15)								(25)	(153.16)	
AR5106A	3/4"	(20)	Thread BSP						250 psig*	451 SCFM	
AR5106B	(20)								17.23 barg*	766 m³/hr	
AR5108A	1"	1 1/4"	Thread BSP	6.88"	2.37"	2.00"	1.90"	3.01"	250 psig*	1,003 SCFM	3.75 (1.70)
AR5108B	(25)								(32)	(174.75)	
AR5112A	1 1/2"	2"	Thread BSP	9.64"	3.20"	2.45"	2.60"	3.89"	250 psig*	2,277 SCFM	8.00 (3.63)
AR5112B	(40)								(50)	(244.86)	

\*Custom psig and barg settings are available

Note: For Non-ASME stamp, the part numbers are: AR5104N, AR5106N, AR5108N, AR5112N.



AR5100 Series

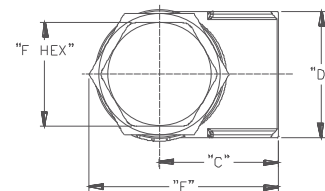
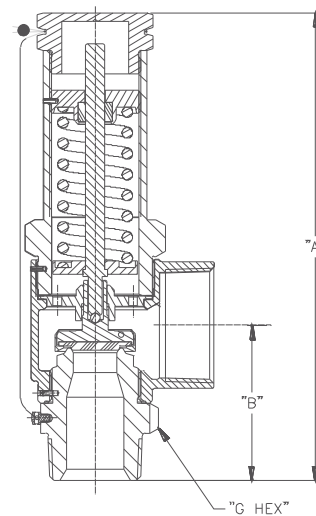

### Air Capacity = m x P

Where:

m = Slope Value

P = Pressure, Absolute @10% overpressure.

Example: Pressure relief valve, 1/2" inlet x 1" outlet, at 80 psi. Part number AR5108A080.

m = 1.4

P = 80 psia

Air Capacity = 1.4 x [(80psia x 1.10) + 14.7]

Air Capacity = 143.8 SCFM (air)

## Flow Performance

AR5104A set pressures 75 - 500 capacity is 1.4 SCFM of air per psi of flow pressure.

AR5106A set pressures 75 - 400 capacity is 1.56 SCFM of air per psi of flow pressure.

AR5108A set pressures 75 - 425 capacity is 3.463 SCFM of air per psi of flow pressure.

AR5112A set pressures 80 - 425 capacity is 7.86 SCFM of air per psi of flow pressure.

Flow pressure per ASME is 10% above set pressure or +3 psi, whichever is greater.

## Pressure Setting and Flow Data AR Series

Pressure Setting and Flow Data AR Series SCFM (air)						
Pressure Setting psig	barg	MPA	AR4104A AR5104A	AR4106A AR5106A	AR4108A AR5108A	AR4112A AR5112A
22	1.5	.15	54	61	135	306
25	1.7	.17	59	66	146	332
30	2.1	.21	67	74	165	375
35	2.4	.24	74	83	184	418
40	2.8	.28	82	91	203	461
45	3.1	.31	90	100	222	505
50	3.4	.34	98	108	241	548
55	3.8	.38	105	117	260	591
60	4.1	.41	113	126	279	634
65	4.5	.45	121	134	299	678
70	4.8	.48	128	143	318	721
75	5.2	.52	136	151	337	764
80	5.5	.55	144	160	356	807
90	6.2	.62	159	177	394	894
100	6.9	.69	175	194	432	980
110	7.6	.76	190	211	470	1067
120	8.3	.83	205	228	508	1153
130	9.0	.90	221	245	546	1240
140	9.7	.97	236	262	584	1326
145	10.0	1.0	244	271	603	1369
150	10.3	1.03	252	280	622	1413
175	12.1	1.21	290	322	718	1629
200	13.8	1.38	329	365	813	1845
225	15.5	1.55	367	408	908	2061
230	15.9	1.59	375	417	927	2104
235	16.2	1.62	382	425	946	2148
240	16.6	1.66	390	434	965	2191
250	17.2	1.72	406	451	1003	2277
260	17.9	1.79	421	468	1041	2364
265	18.3	1.83	429	476	1060	2407
275	19.0	1.90	444	494	1098	2494
280	19.3	1.93	452	502	1118	2537
285	19.7	1.97	459	511	1137	2580
290	20.0	2.0	467	519	1156	2623
295	20.3	2.03	475	528	1175	2666
300	20.7	2.07	483	536	1194	2710
325	22.4	2.24	521	579	1289	2926
350	24.1	2.41	560	622	1384	3142
375	25.9	2.59	598	665	1479	3358
400	27.6	2.76	637	708	1575	3574
425	29.3	2.93	675	750	1670	3791
450	31.0	3.1	714	793	1765	4007
475	32.8	3.28	752	836	1860	4223
500	34.5	3.45	791	879	1956	4439
525	36.2	3.62	829	921	2051	4655
550	37.9	3.79	868	964	2146	4871